

PVR1T Series Single Vane Pumps

These Pumps are widely used as a source of hydraulic power. They combine stable performance and robust construction with a wide range of delivery rates.

Graphic Symbol



Specifications

Model Number	Geometric Displacement cm ³ /rev.	Max. Opr. Pressure Kgf/cm ²	Output Flow and Input Power	Shaft Speed Range r/min.		Mass (Approx.) Kg.	
				Max.	Min.	Flange Mounting	Foot Mounting
PVR1T-4	3.5	125	Refer to Page 110 & 111	1800	750	5.8	7.5
PVR1T-6	5.5						
PVR1T-8	7.8						
PVR1T-10	8.7						
PVR1T-12	11.5						
PVR1T-15	13.8						
PVR1T-17	16.0						
PVR1T-31	22.0					6.2	8.0

Model Number Designation

Material	Model	Displacement	Mounting	Rotation	Porting	Mass	Designation
F: For Phosphate Ester Type Fluids (Omit if not required)	PVR1T	4, 6, 8, 10, 12, 15, 17	L: Foot Type F: Flange Type	R: Clock wise (Normal) L: Counter Clockwise		20	80
		31					80H10

* Design numbers subject to change from 20 to 29, but installation dimensions remain as shown.

* For instructions regarding changing the port positions, consult CNIP INDIA LTD.

** Before ordering the Special Seals, consult CNIP INDIA LTD.

Cartridge Kit Model Number

CPVR1T	-4	-R	-20
Model Number	Nominal Delivery	Shaft Rotation	Design No.
CPVR1T	4, 6, 8, 10, 12, 15, 17, 31	R: Clockwise (Normal) L: Counter-Clockwise	20

* For instructions regarding replacing cartridge kit, consult CNIP INDIA LTD.

PVR1T-~~F~~-~~2080~~

DIMENSIONS IN MILLIMETRES

● Flange Mounting

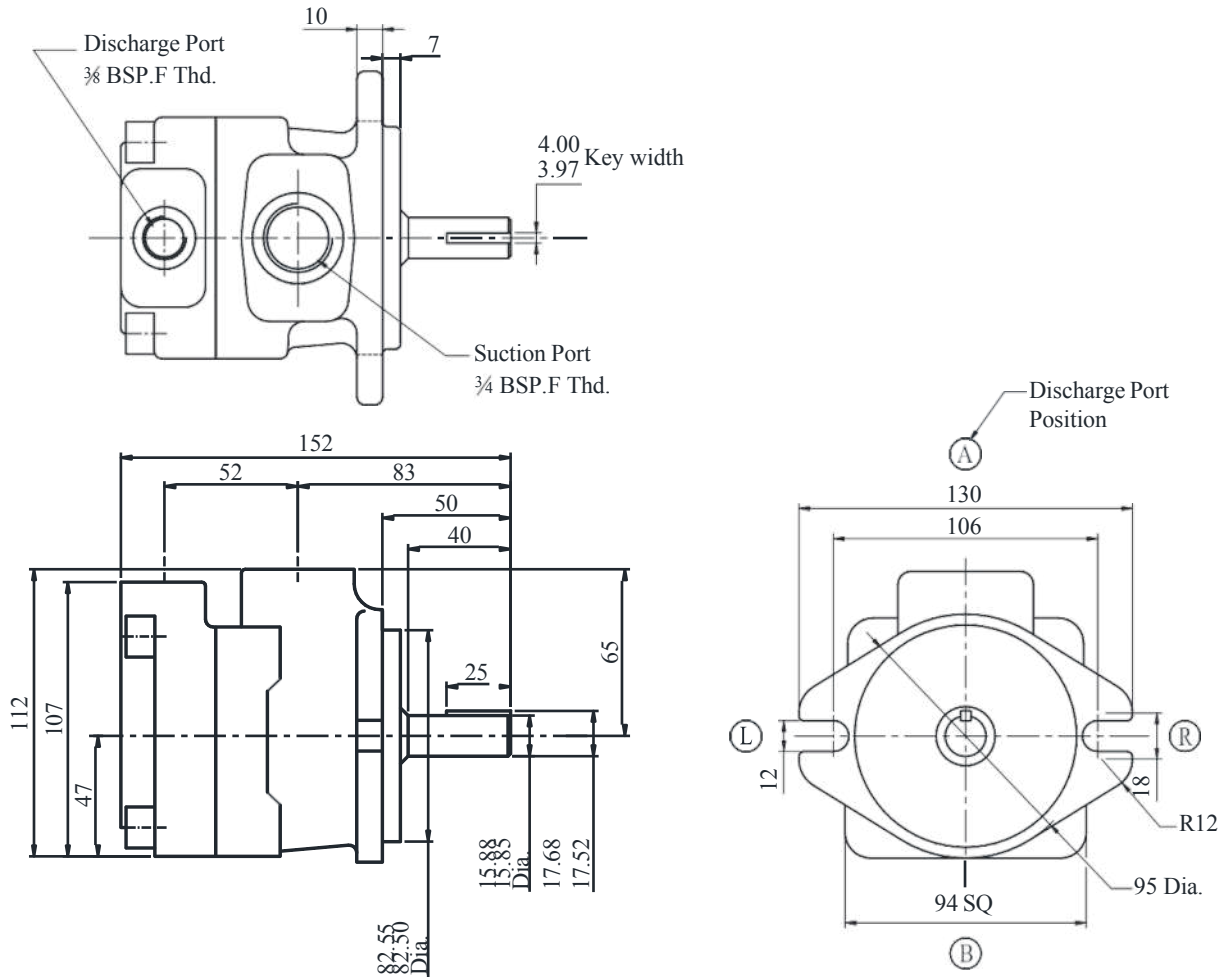

PVR1T-~~L~~-~~2080~~

● Foot Mounting

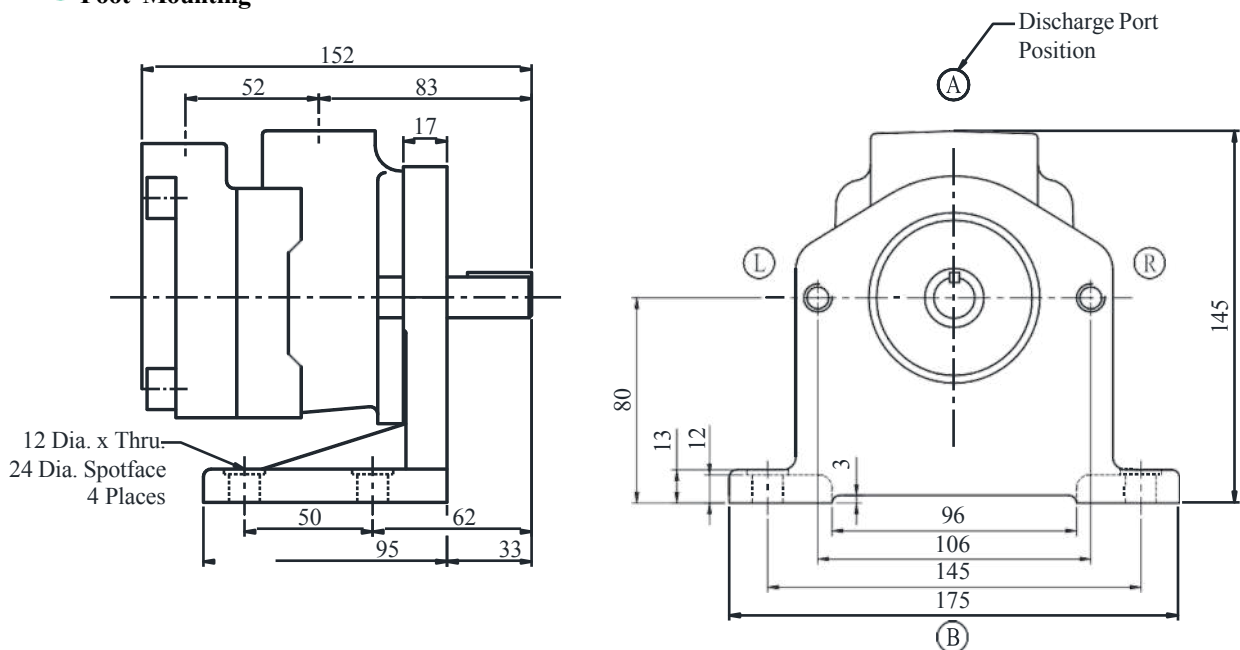

PVR1T-31-F-***-2080H10

● Flange Mounting

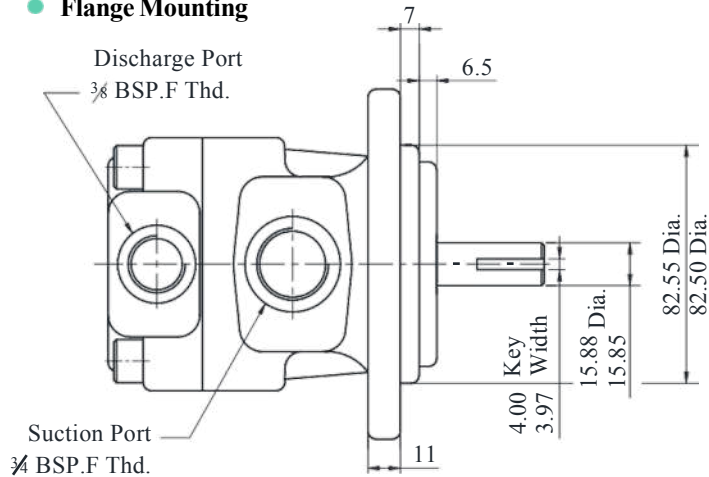

DIMENSIONS IN
MILLIMETRES

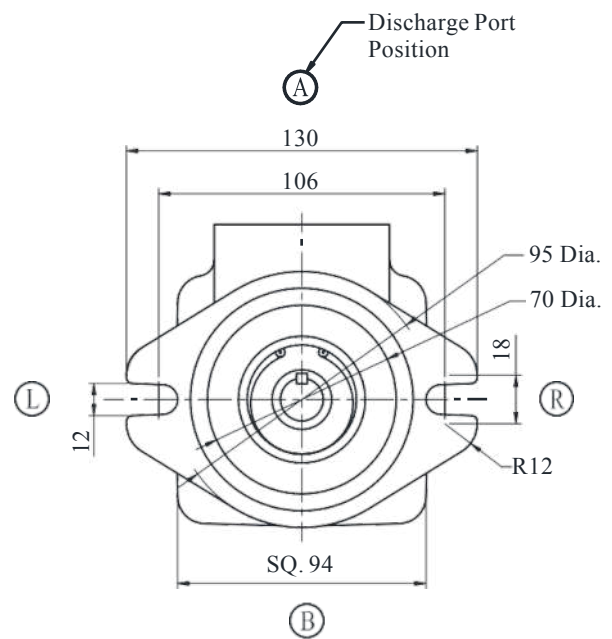
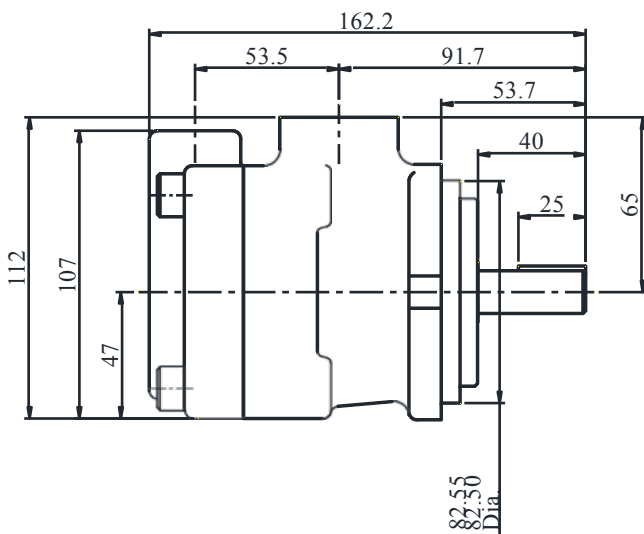

PVR1T-31-L-***-2080H10

● Foot Mounting

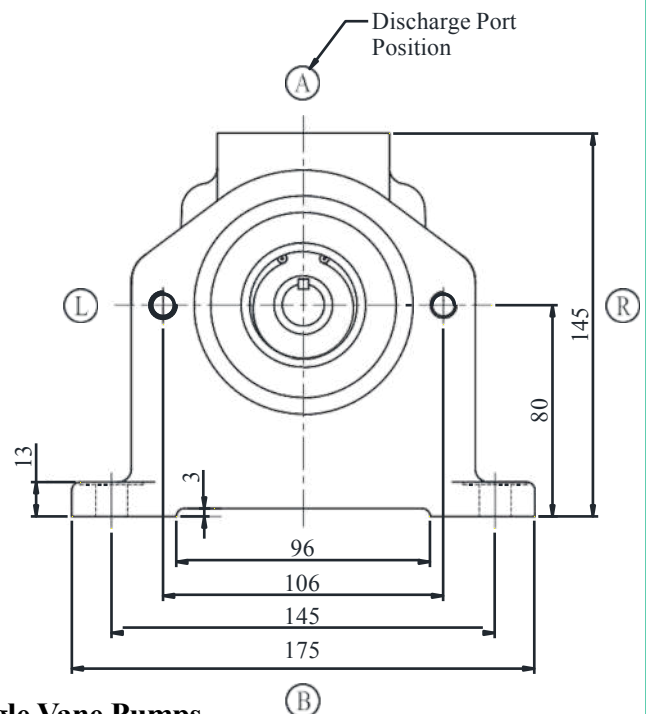
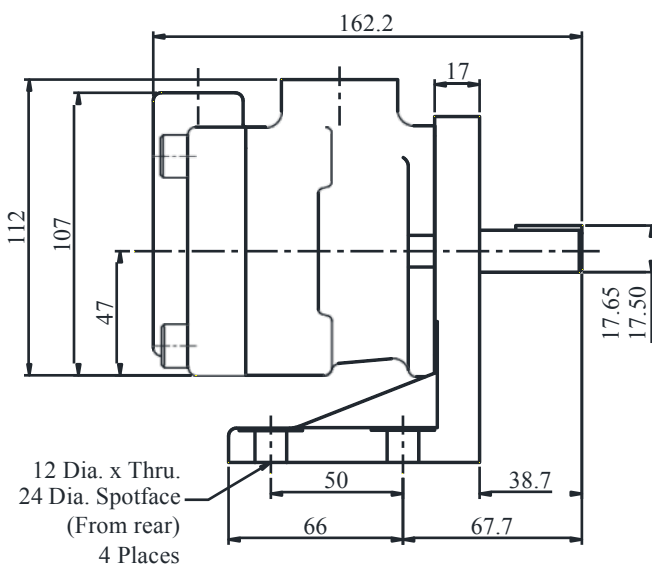

Typical Pump Characteristics Oil Viscosity 20 cSt [ISO VG 32, Temp 50° C]

● PVR1T - 4

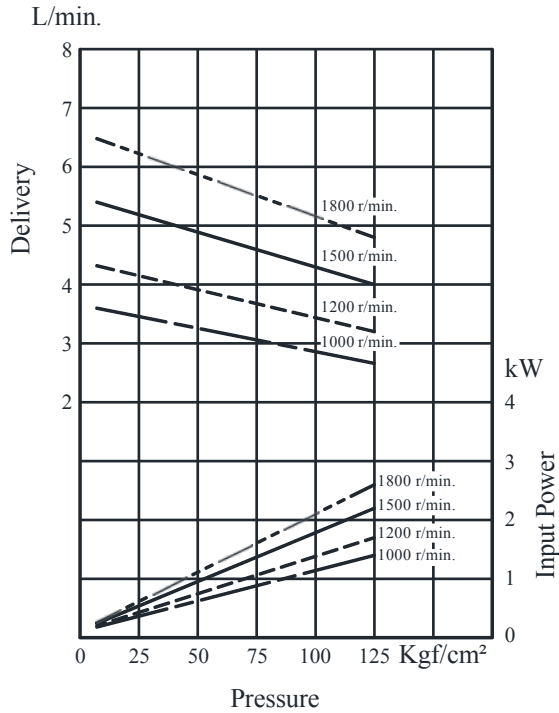

● PVR1T - 6

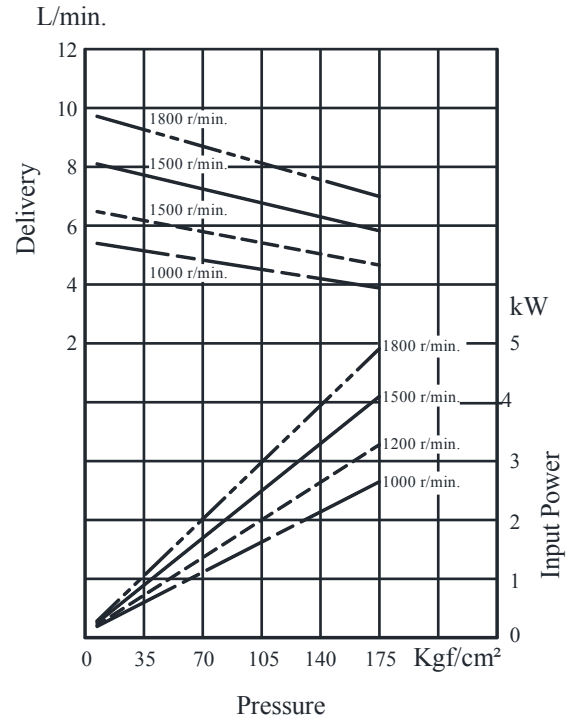

● PVR1T - 8

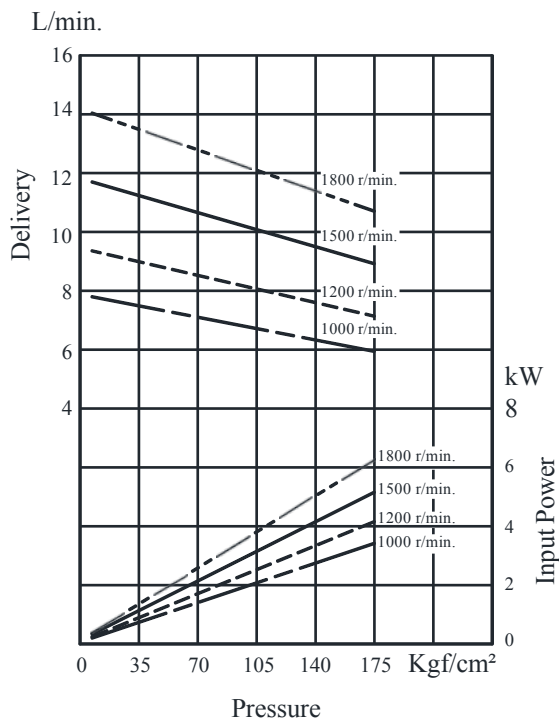

● PVR1T - 10

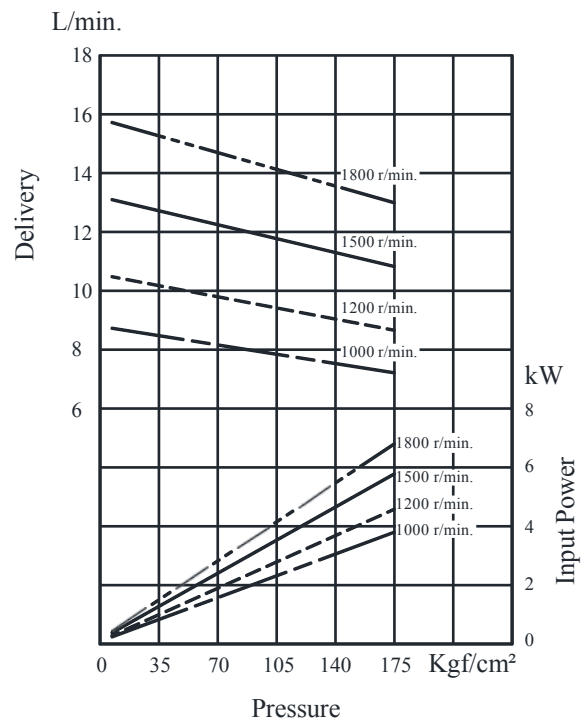

Typical Pump Characteristics Oil Viscosity 20 cSt [ISO VG 32, Temp 50° C]

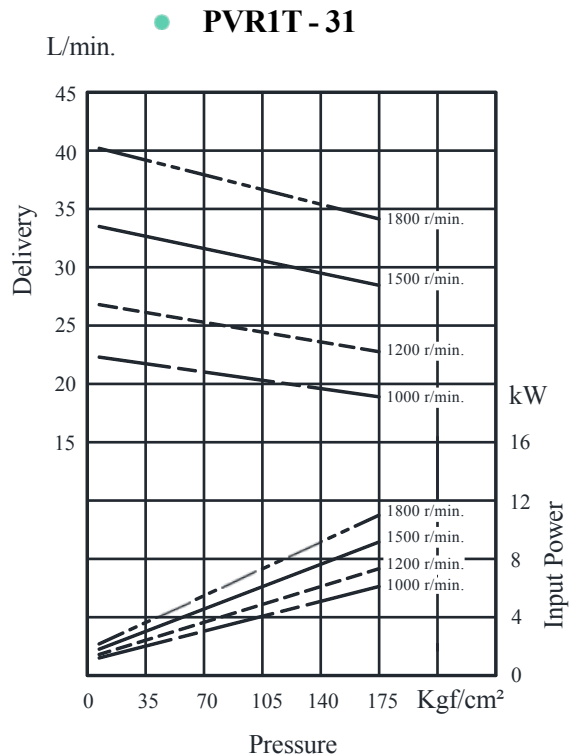
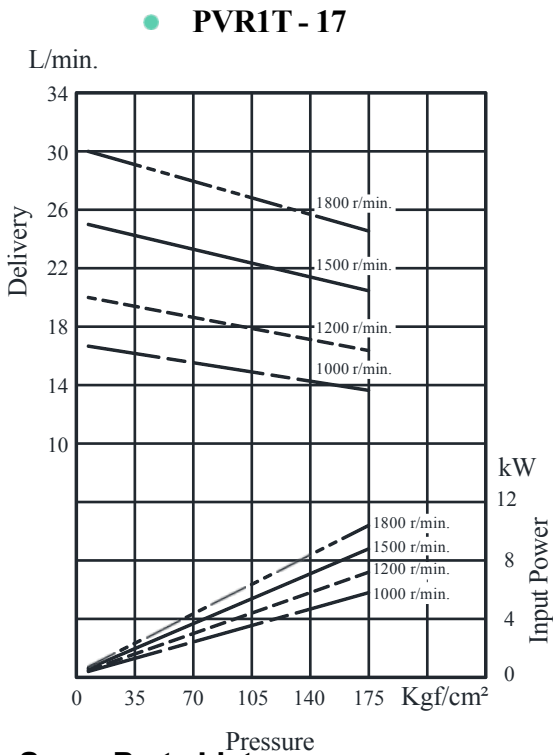
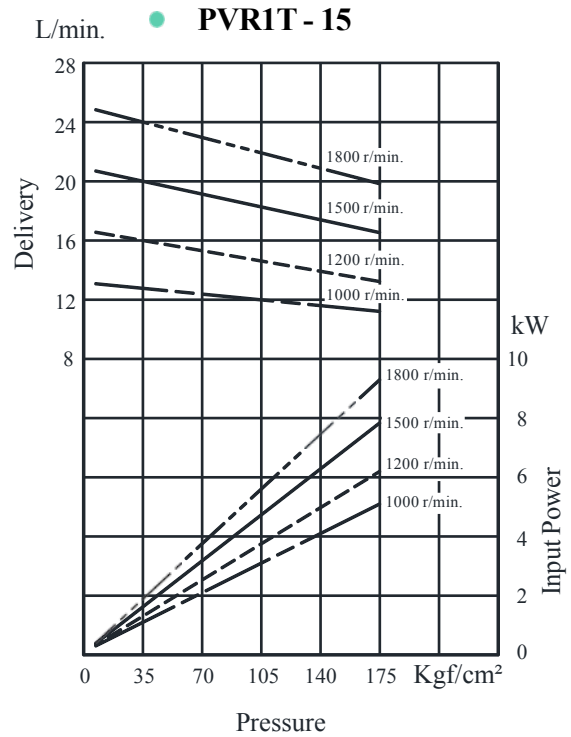
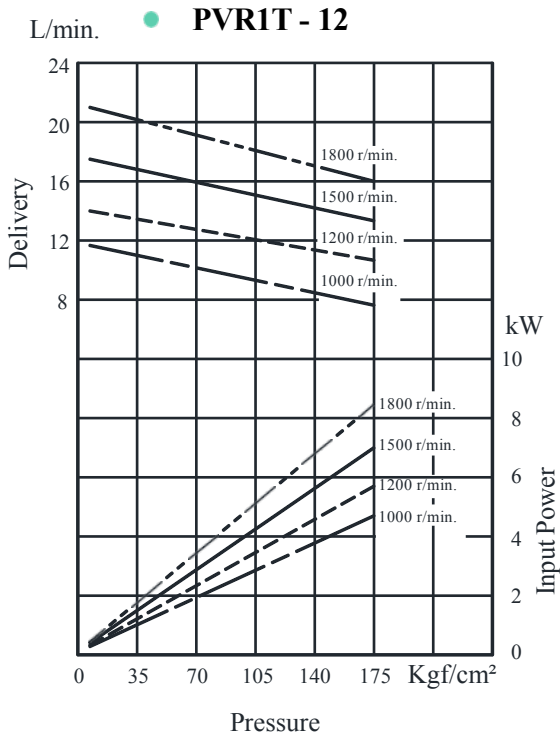

Spare Parts List

List of Seals

Sl. No.	Name of Parts	Part No.	Qty.
1.	O-Ring	SO-NB-G80	1
2.	O-Ring	SO-NB-G60	1
3.	O-Ring	SO-NB-G35	1
4.	Oil seal	ISD 20307	1

Note : When ordering the seals, please specify the seal kit number KS-PVR1T-2080.

“PVR” Series Single Vane Pumps

B

PVR Series
Single Vane Pumps

PVR50 Series Single Vane Pumps

These pumps are widely used as a source of hydraulic power. They combine stable Performance and robust construction with a wide range of delivery rates.

Graphic Symbol

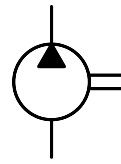

Specifications

Model Number	Geometric Displacement cm ³ /rev.	Max. Opr. Pressure Kgf/cm ²	Output Flow and Input Power	Shaft Speed Range r/min.		Mass (Approx.) Kg.	
				Max.	Min.	Flange Mounting	Foot Mounting
PVR50-13	10.5	175	Ref. Page 110, 111 & 112	1800	600	12	14.7
PVR50-20	16.0						
PVR50-26	21.5						
PVR50-30	24.0						
PVR50-36	29.5						
PVR50-39	31.5						
PVR50-45	35.5						
PVR50-51	41.0						
PVR50-56	45.0						

Model Number Designation

F-	PVR50	-L	-F	-13	-	-R	A	A	-31	80
Special Seals **	Series Number	Type of Mounting	Type of Pipe Connection	Nominal Delivery	Shaft Type	Direction of Rotation	Discharge Port Position	Suction Port Position	Design * Number	Design Standard
						As Viewed From Shaft End				
F: For Phosphate Ester Type Fluids (Omit if not required)	PVR50	L: Foot Type F: Flange Type	F: Flange Connection T: Threaded Connection	13 20 26 30 36 39 45 51 56 *1	None: Std. Shaft. 1: Special Shaft (For 51 & 56 Capacity Only)	R: Clockwise (Normal) L: Counter Clockwise			31	80

* Design numbers subject to change from 30 to 39, but installation dimensions remain as shown.

* For instructions regarding changing the port positions, consult CNIP INDIA LTD.

** Before ordering the Special Seals, consult CNIP INDIA LTD.

*1 Threaded type connection is not available for 56 Capacity.

Cartridge Kit Model Number

CPVR50	-13	-R	-31
Model Number	Nominal Delivery	Shaft Rotation	Design No.
CPVR50	13, 20 26, 30 36, 39 45, 51 56	R: Clockwise (Normal) L: Counter-Clockwise	31

* For instructions regarding replacing cartridge kit, consult CNIP INDIA LTD.

PVR50-F-※-※-※※※-3180

● Flange Mounting

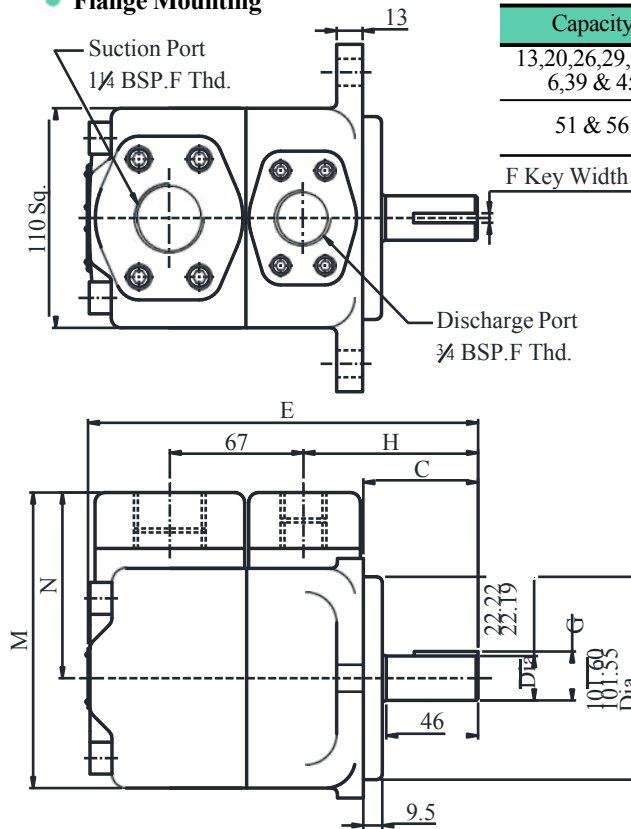

Capacity	A	B	C	D	E	F	G	H
13,20,26,29,30,36,39 & 45	74	42	59	32	197	4.79 4.76	24.500 24.330	87.5
51 & 56	86.4	54.4	71.4	38	209.4	6.38 6.35	24.925 24.774	100

Model	M	N
PVR50-※-F-	148	93
PVR50-※-T-	136	81

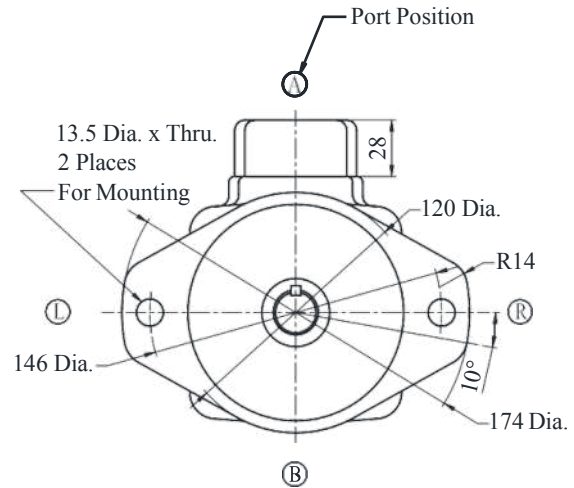

PVR50-L-※-※-※※※-3180

● Foot Mounting

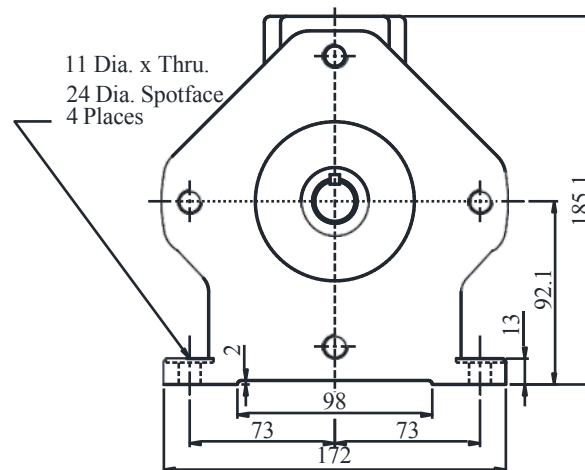
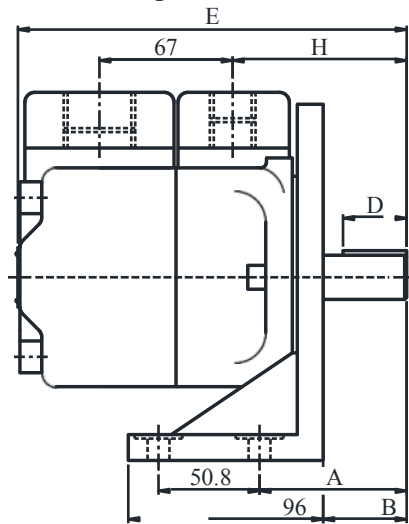

DIMENSIONS IN MILLIMETRES

For Other Dimensions see Flange Mounting.

For Reference: Dimensions of Pipe Flange Mounting Surfaces

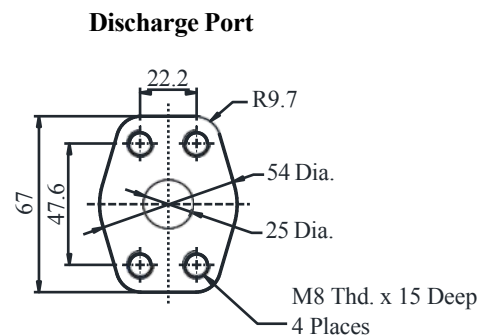
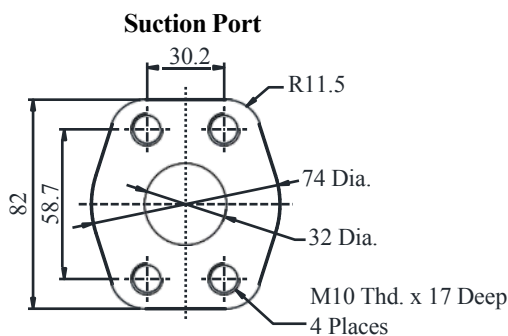

“PVR” Series Single Vane Pumps

B

PVR Series
Single Vane Pumps

Typical Pump Characteristics Oil Viscosity 20 cSt [ISO VG 32, Temp 50° C]

● PVR50 - 13

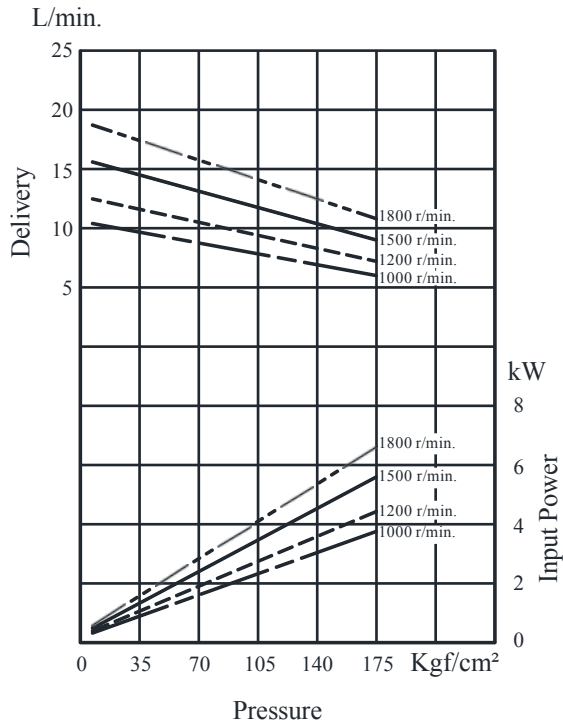

● PVR50 - 20

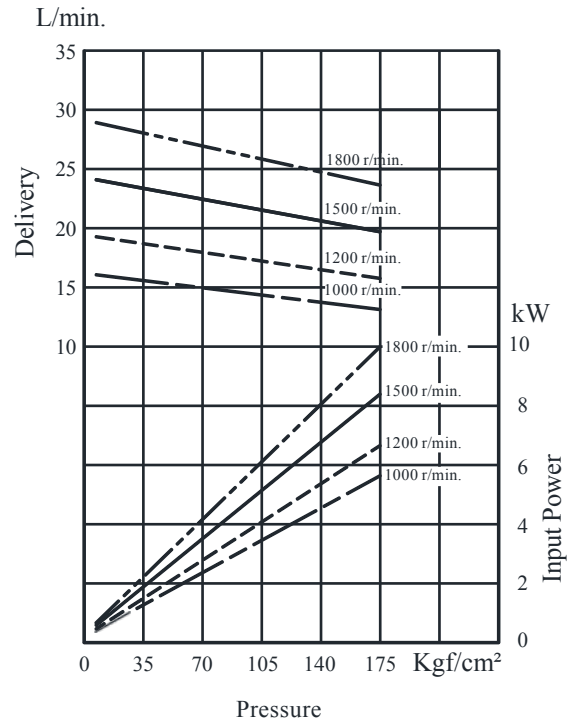

● PVR50 - 26

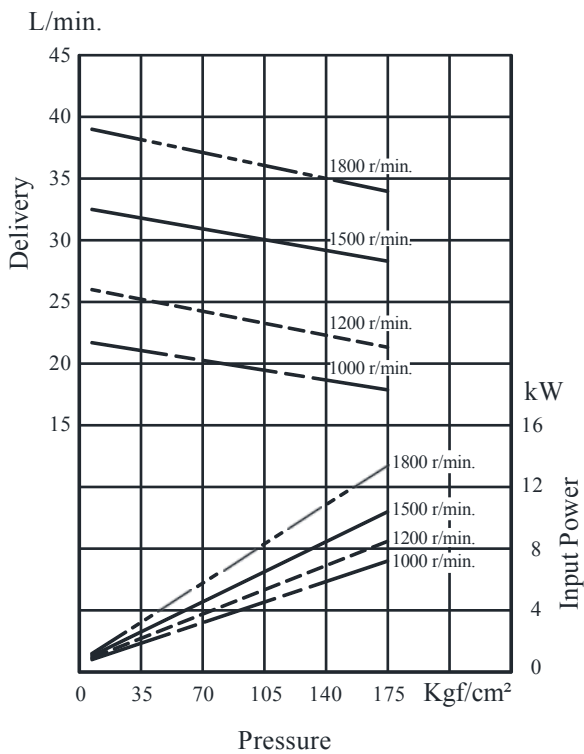

● PVR50 - 30

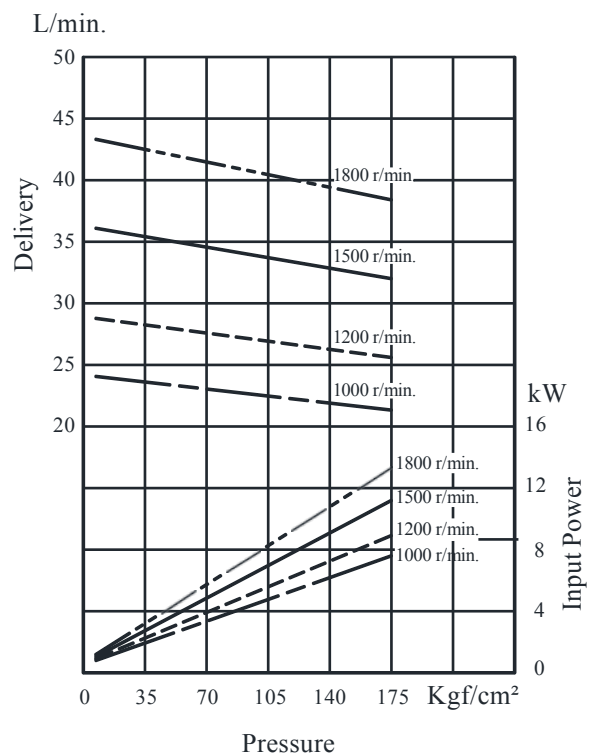

Typical Pump Characteristics Oil Viscosity 20 cSt [ISO VG 32, Temp 50° C]

● PVR50 - 36

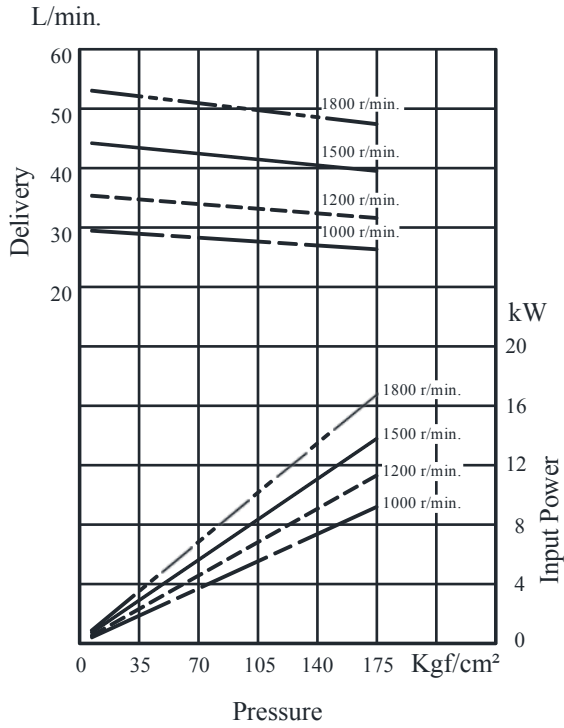

● PVR50 - 39

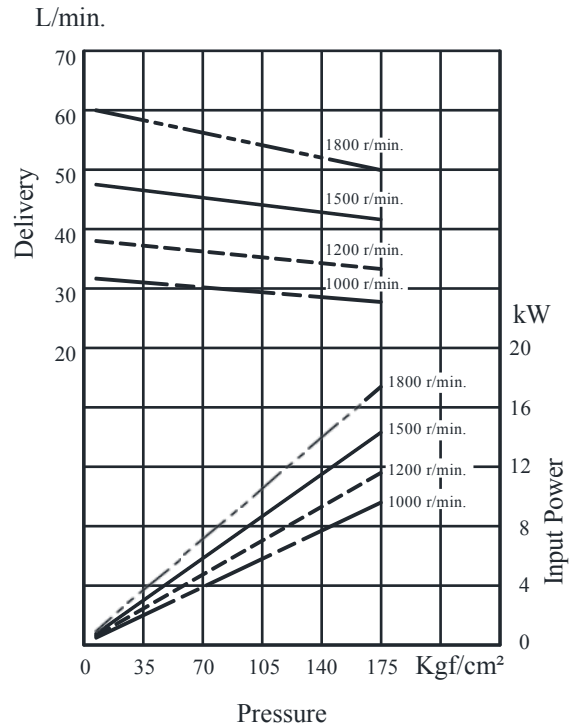

● PVR50 - 45

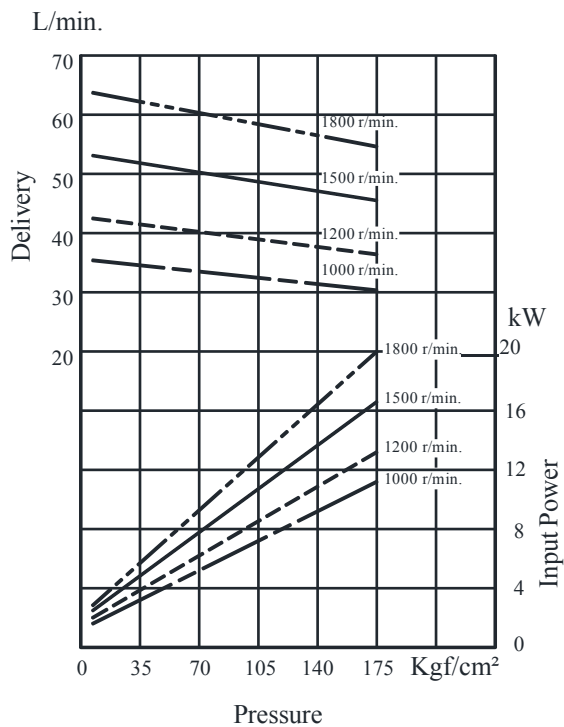

● PVR50 - 51

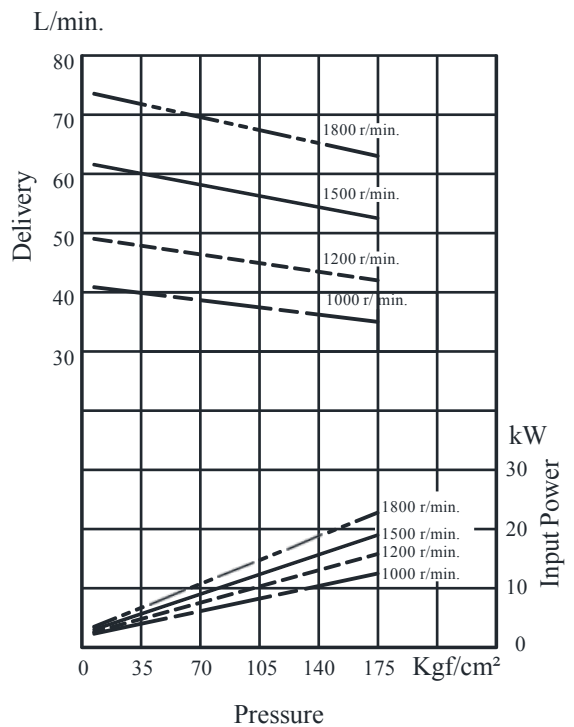

B

PVR Series
Single Vane Pumps

Typical Pump Characteristics Oil Viscosity 20 cSt [ISO VG 32, Temp 50° C]

● PVR50 - 56

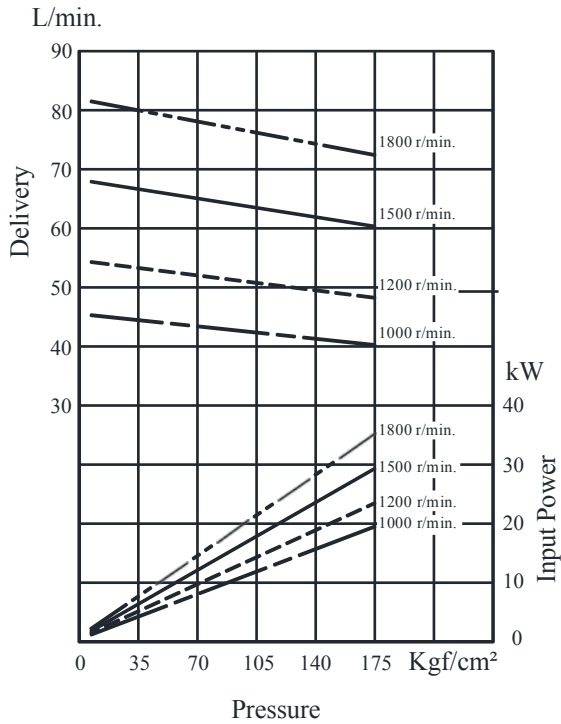

■ Flanges

Note: Please refer page no. 725 for flange details.

■ Spare Parts List

● List of Seals

Sl. No.	Name of Part	Part Number	Qty.
1	O-Ring	SO-NA-G80	1
2	O-Ring	SO-NA-P41	1
3	O-Ring	SO-NB-G85	1
4	Backup-Ring	SO-BB-G80	1
5	Backup-Ring	SO-BB-P41	1
6	Oil Seal	ISPD 25388	1

Note: When ordering the seals, please specify the seal kit number KS-PVR50-3180.

PVR 150-Series Single Vane Pumps

These pumps are widely used as a source of hydraulic power. They combine stable performance and robust construction with a wide range of delivery rates.



Graphic Symbol

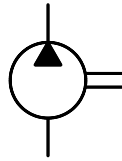

Specifications

Model Number	Geometric Displacement cm ³ /rev.	Max. Opr. Pressure Kg/cm ²	Output Flow and Input Power	Shaft Speed Range r/min.		Mass (Approx.) Kg.	
				Max.	Min.	Flange Mounting	Foot Mounting
PVR150 – 60	47	175	Refer Page 115 & 116	1800*	600	29.3	35.9
PVR150 – 70	57						
PVR150 – 90	75						
PVR150 – 110	92						
PVR150 – 140	115						
PVR150 – 170	135						

* For speeds above 1500 r/min., consult factory for information.

Model Number Designation

F-	PVR150	-L	-F	-60	-R	A	A	-34	80
Special Seals **	Series Number	Type of Mounting	Type of pipe Connection	Nominal Delivery	Direction of Rotation	Discharge Port Position	Suction Port Position	Design *	Design Standard
						As Viewed From Shaft End			
F: For Phosphate Ester Type Fluids (Omit if not required)	PVR150	L: Foot Type F: Flange Type	F: Flange Connection	60 70 90 110 140 170	R: Clockwise (Normal) L: Counter Clockwise			34	80

* Design numbers subject to change from 30 to 39, but installation dimensions remain as shown.

* For instructions regarding changing the port positions, consult CNIP INDIA LTD.

** Before ordering the Special Seals, consult CNIP INDIA LTD.

Cartridge Kit Model Number

CPVR150	-60	-R	-33
Model Number	Nominal Delivery	Shaft Rotation	Design No.
CPVR150	60	R: Clockwise (Normal)	33
	70		
	90		
	110	L: Counter-Clockwise	
	140		
170			

* For instructions regarding replacing cartridge kit, consult CNIP INDIA LTD.

PVR150-F-F-※-※※※-3480

● Flange Mounting

DIMENSIONS IN MILLIMETRES

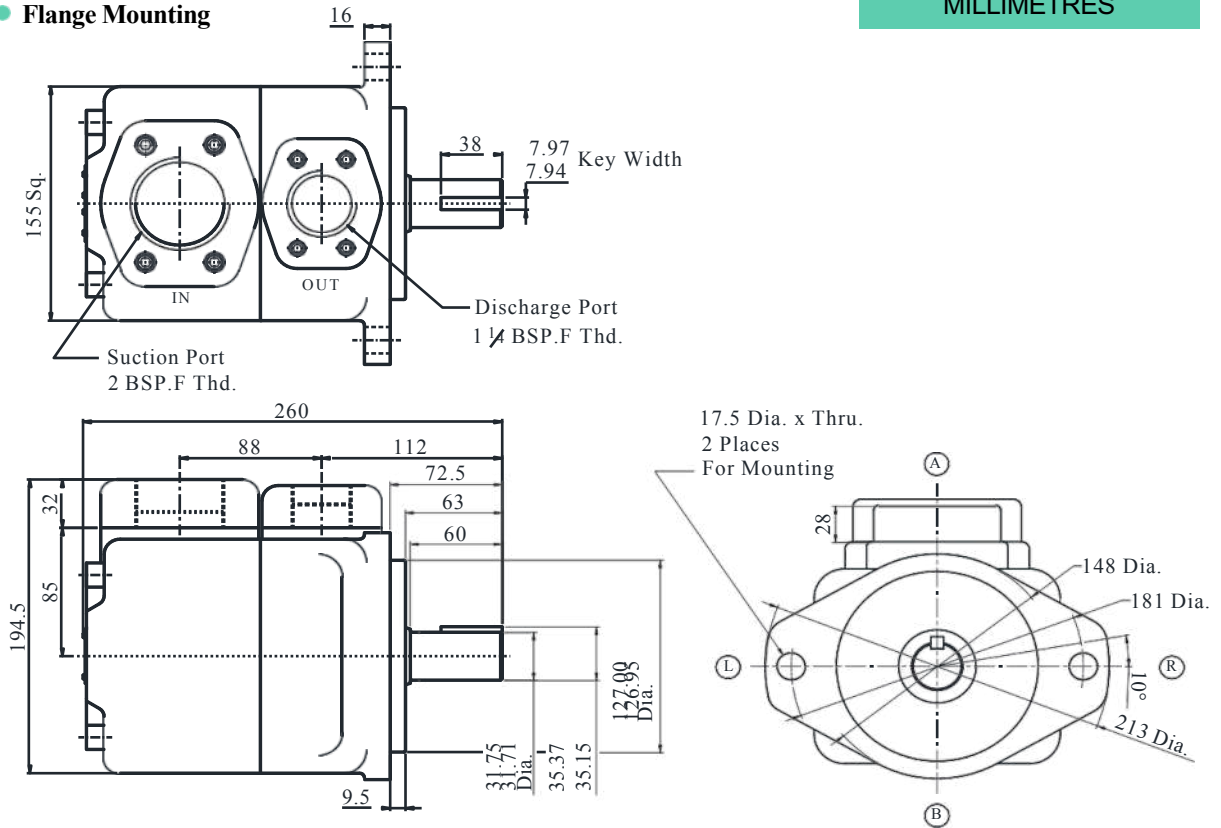

PVR150-L-F-※-※※※-3480

● Foot Mounting

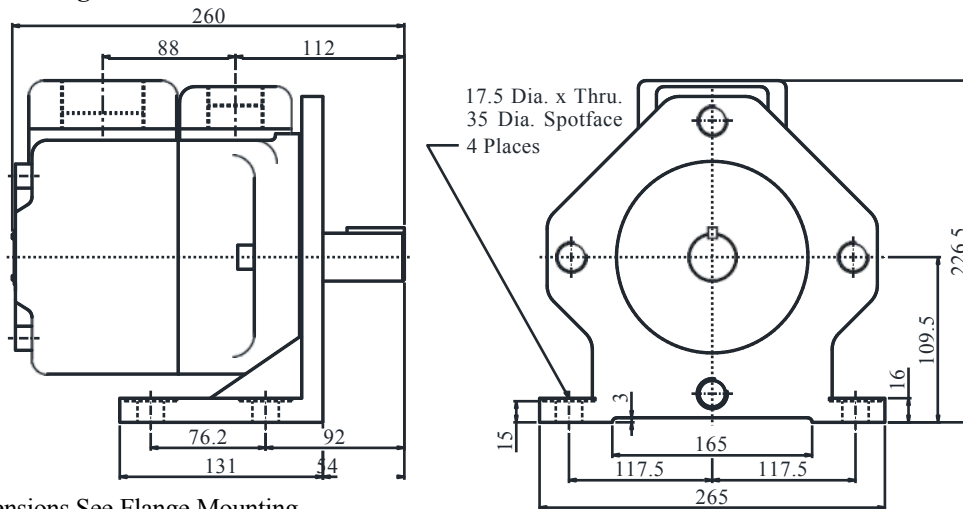

For other Dimensions See Flange Mounting

For Reference : Dimensions of Pipe Flange Mounting Surfaces

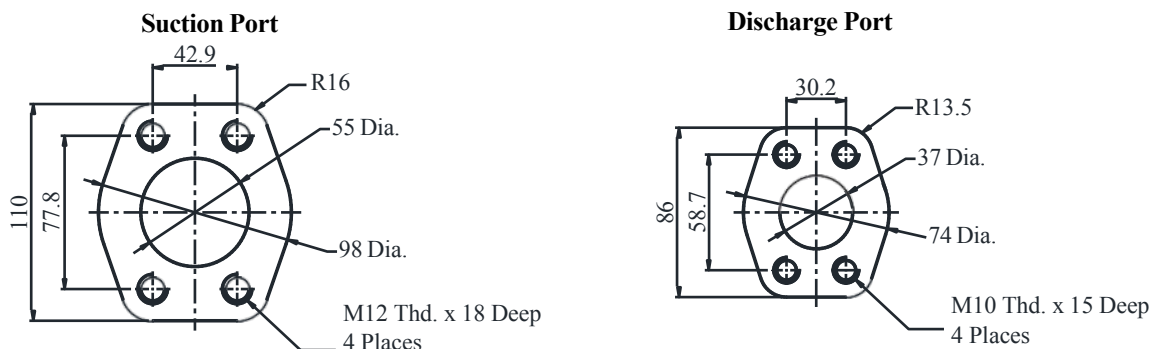

“PVR” Series Single Vane Pumps

Typical Pump Characteristics Oil Viscosity 20 cSt [ISO VG 32, Temp 50° C]

● PVR 150 - 60

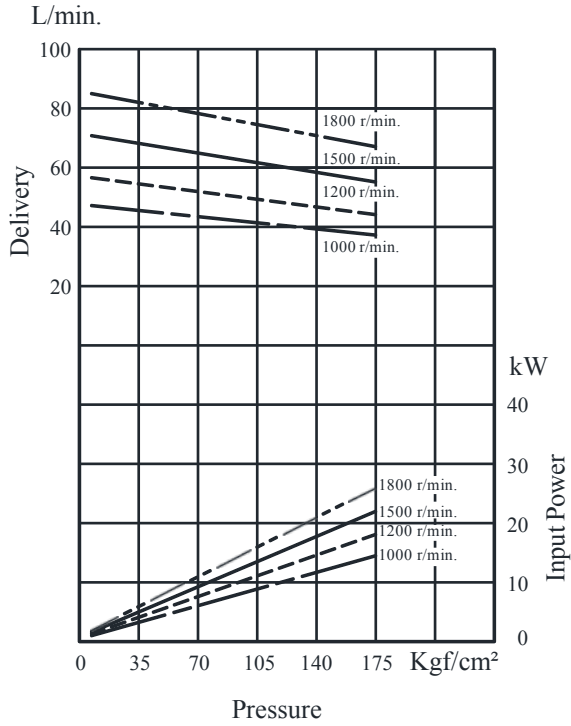

● PVR 150 - 70

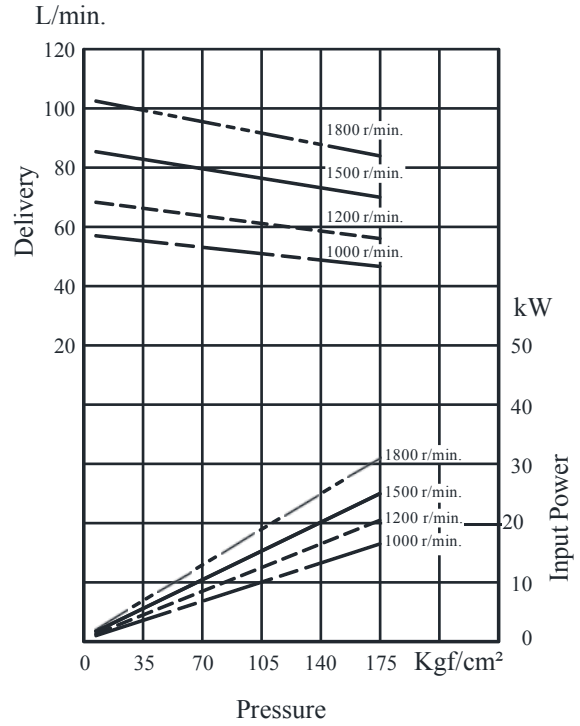

● PVR 150 - 90

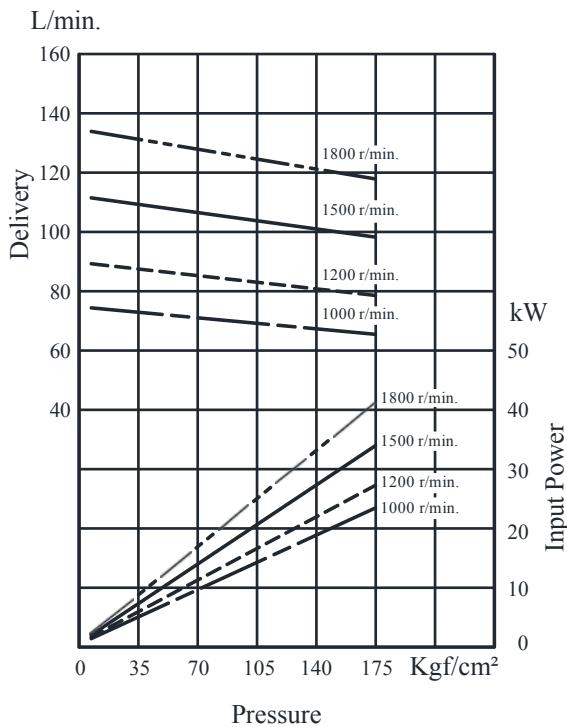

● PVR 150 - 110

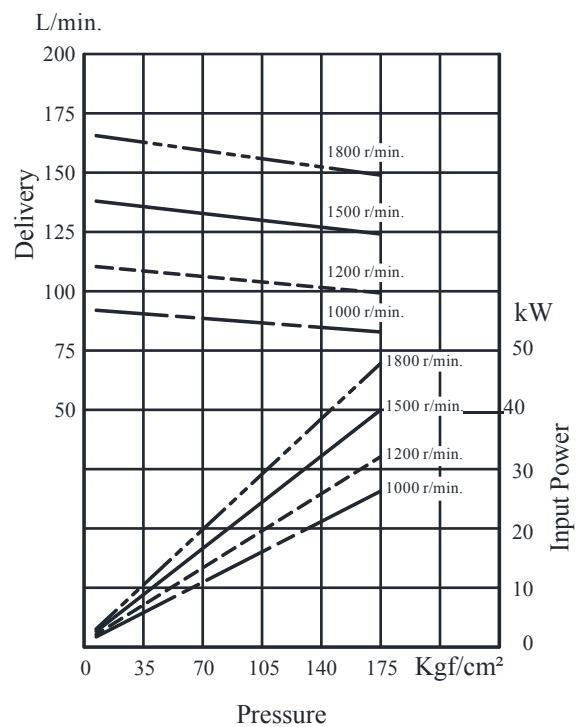

Typical Pump Characteristics Oil Viscosity 20 cSt [ISO VG 32, Temp 50° C]

● PVR 150 - 140

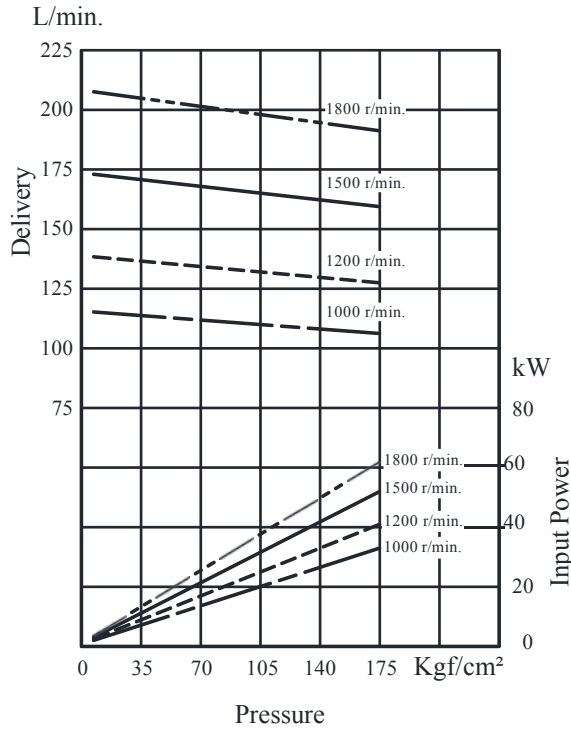

● PVR 150 - 170

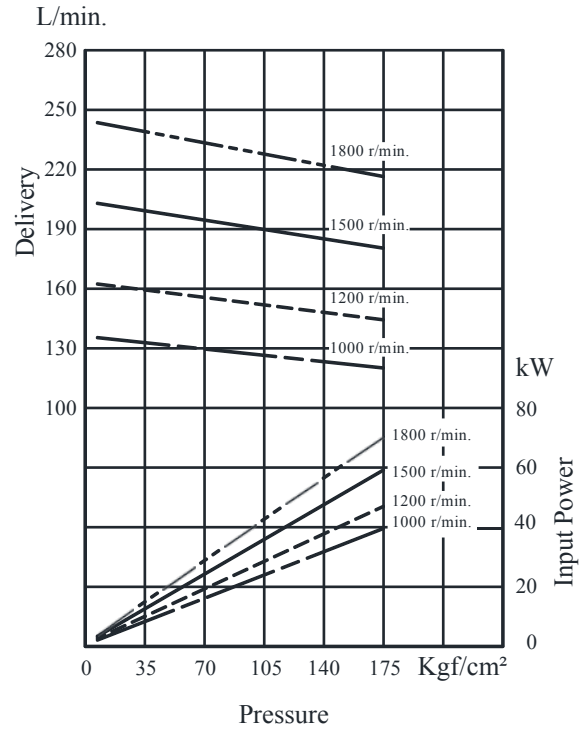

■ Spare Parts List

● List of Seals

Sl. No.	Name of Part	Part number	Qty.
1	O-Ring	SO-NA-G120Y	1
2	O-Ring	ARP568231	1
3	O-Ring	SO-NB-G125	1
4	Backup-Ring	JISW1516-G9	1
5	Backup-Ring	SO-BB-G120	1
6	Oil Seal	TC38558-7	1

Note: When ordering the seals, please specify the seal kit number KS-PVR150-3480.

■ Flanges

Note: Please refer page no. 749 for flange details.

■ Cartridge Kit Model Number

Pump Model Numbers	Cartridge Kit Number #
PVR1T-6-※-R※-2080	CPVR1T-06-R-20
PVR1T-10-※-R※-2080	CPVR1T-10-R-20
PVR1T-15-※-R※-2080	CPVR1T-15-R-20
PVR50-※-※-20-R※※-3180	CPVR50-20-R-31
PVR50-※-※-36-R※※-3180	CPVR50-36-R-31
PVR50-※-※-45-R※※-3180	CPVR50-45-R-31
PVR150-※-F-70-R※※-3480	CPVR150-70-R-33
PVR150-※-F-110-R※※-3480	CPVR150-110-R-33

* For instructions regarding replacing cartridge kit, consult CNIP INDIA LTD.

The above table does not include all combinations of cartridges available.

Only a few representative samples are shown.

“PVR” Series Single Vane Pumps