

PG00-Series Gear Pumps

- High strength extruded aluminum body.
- Hardened and ground integral gear shaft.
- Special aluminum alloy bush bearing.
- Axially balanced for high volumetric efficiency in excess of 95%.
- Pumps suitable for manifold mounting and tang drive.



Specifications

Model Number	Geometric Displacement cm ³ /rev.	Maximum Pressure Kg/cm ²		Shaft Speed Range r/min.		Mass (Kg) (Approx.)
		Continuous	Intermittent	Max.	Min.	
PG00-100	1.0	200	210	3000	1000	0.75
PG00-160	1.6			3000	800	
PG00-210	2.1			3000	800	
PG00-320	3.2	180	200	3000	600	
PG00-420	4.2					
PG00-530	5.3					
PG00-640	6.4	160	180			

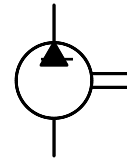

Graphic Symbol

Model Number Designation

PG00	-100	-G	-5	-P	-B	-R	-30	80
Series	Size	Shaft	Mounting	Port	Drive Shaft Seal	Direction of Rotation (Viewed from Shaft End)	Design Number	Design Std.
PG00	100	G:Tang	5: With Ø30.5 Spigot Mounting 6: With Ø32 Spigot Mounting	P: BSPF Port PO: O Ring port	B: Nitrile V:*1 Viton	R: Clockwise L: Counter Clockwise	30	80
	160							
	210							
	320							
	420							
	530							
640								

*1 Consult factory for availability.

Spare Parts List

List of Seals

Sl No.	Name of Parts	Part Numbers		Qty.
		Nitrile	Viton	
1	Back up seal	A200 01 35	A200 01 35	2
2	Body End Seal	A200 01 34	A200 01 36	2
3	Oil Seal	A200 01 13	A200 01 23	1

Seals

B: Nitrile (Temp. range:- 15°C + 80°C)
V: Viton (Temp. range:- 10°C + 140°C)

Note: When ordering the seals, please specify the seal kit number
KS-PG00-B for Nitrile
KS-PG00-V for Viton

General Arrangement

Back Port

DIMENSIONS IN MILLIMETRES

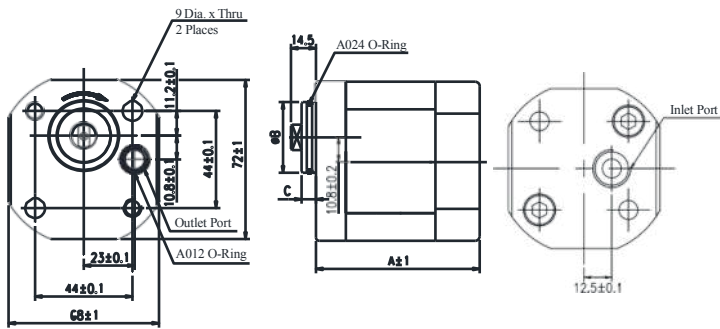

Model Number	A	Ø30.5 Spigot Mounting		Ø32 Spigot Mounting	
		ØB	C	ØB	C
PG00 - 100	65.2	30.460 30.431	8	31.975 31.936	6.5
PG00 - 160	67.9				
PG00 - 210	70.1				
PG00 - 320	74.1				
PG00 - 420	77.8				
PG00 - 530	82.3				
PG00 - 640	87.3				

Side Port

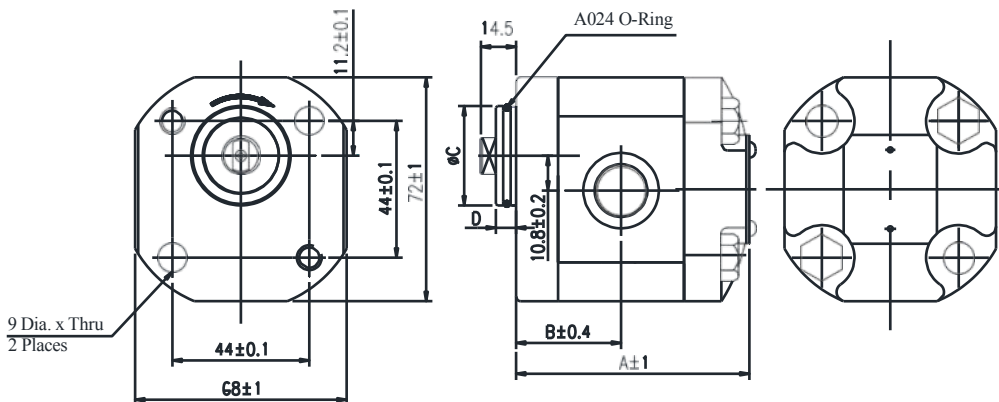

Model Number	A	B	Ø30.5 Spigot Mounting		Ø32 Spigot Mounting	
			ØC	D	ØC	D
PG00 - 100	65.2	29.4	30.460 30.431	8	31.975 31.936	6.5
PG00 - 160	67.9	30.7				
PG00 - 210	70.1	31.8				
PG00 - 320	74.1	33.8				
PG00 - 420	77.8	35.6				
PG00 - 530	82.3	37.9				
PG00 - 640	87.3	40.4				

Shaft Details

G: Tang Shaft

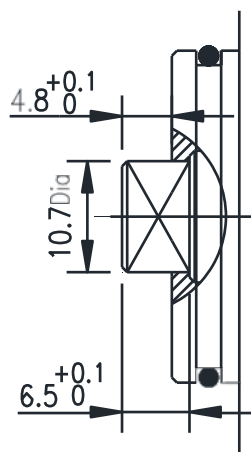
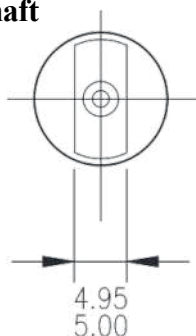

Ports

DIMENSIONS IN MILLIMETRES

Model Number	P: BSP.F Ports		PO: O-Ring Ports	
	Inlet	Outlet	Inlet	Outlet
PG00-100	3/8"	3/8"	3/8"	Ø8
PG00-160	3/8"	3/8"	3/8"	Ø8
PG00-210	3/8"	3/8"	3/8"	Ø8
PG00-320	3/8"	3/8"	3/8"	Ø8
PG00-420	1/2"	1/2"	1/2"	Ø8
PG00-530	1/2"	1/2"	1/2"	Ø8
PG00-640	1/2"	1/2"	1/2"	Ø8

Speed Vs. Flow

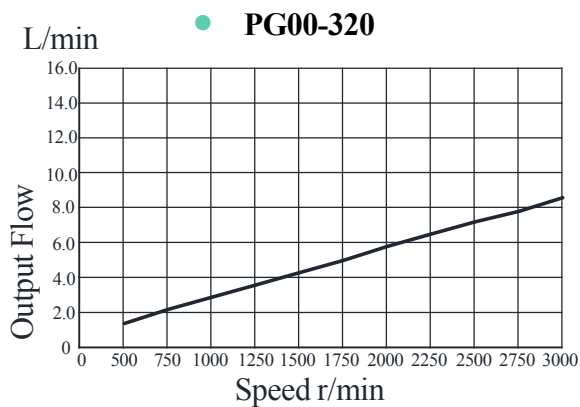
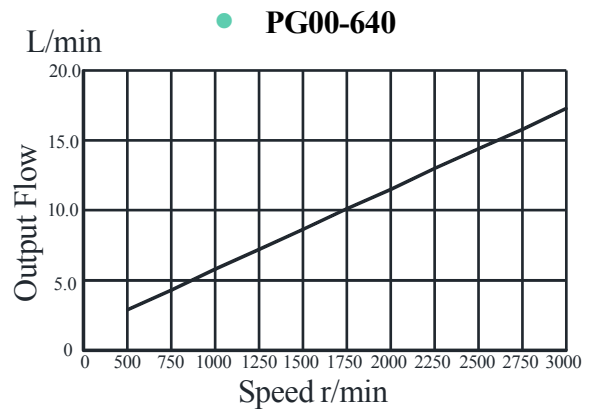
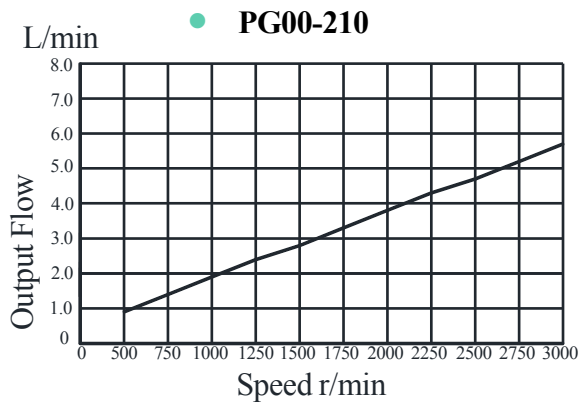
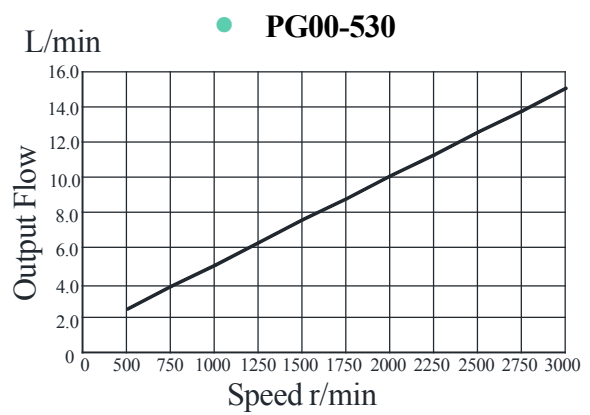
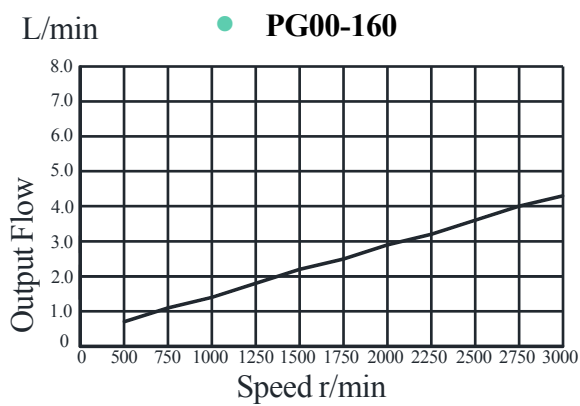
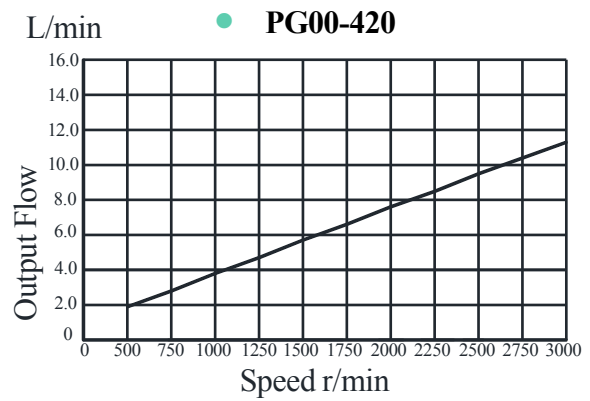
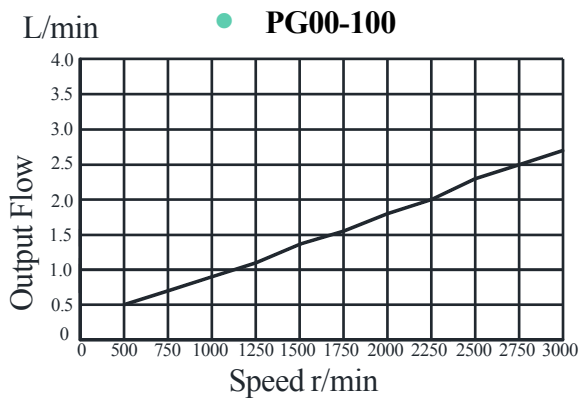

Pressure Vs. Input Power

● PG00-100

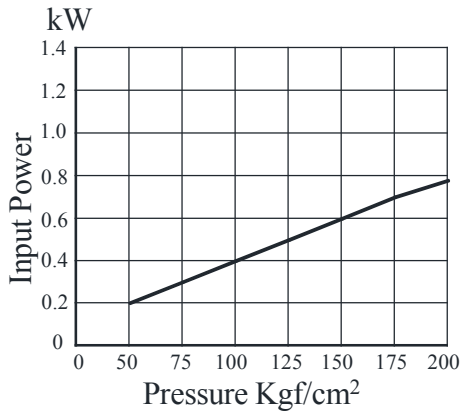

● PG00-420

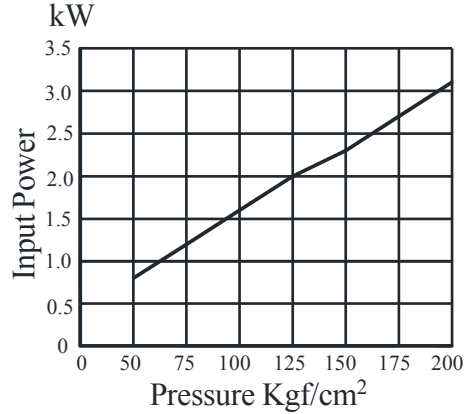

● PG00-160

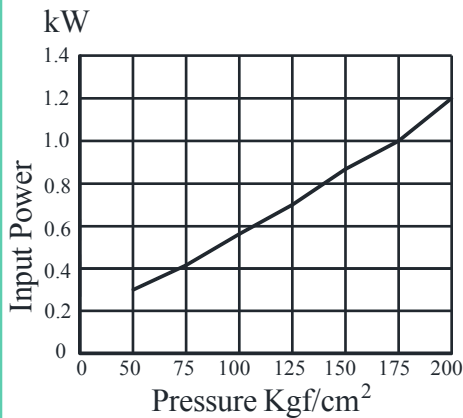

● PG00-530

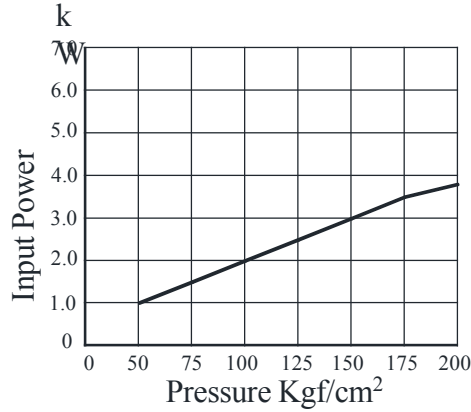

● PG00-210

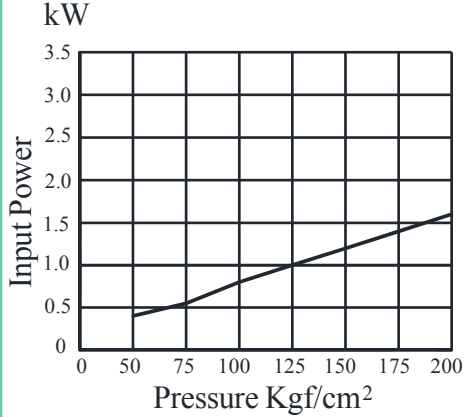

● PG00-640

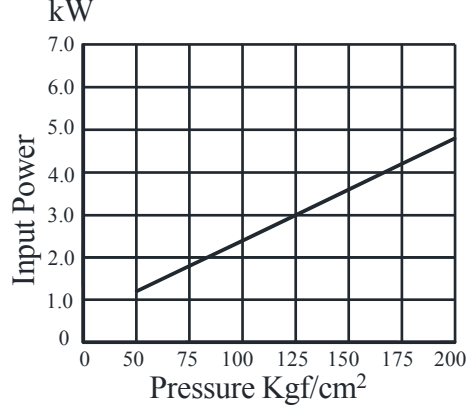

● PG00-320

